

The Teflon handheld sensor was designed for food and pharmaceutical applications. It is virtually free of bacterial microniches and is completely submersible so may be washed and autoclaved.

- Standard ( Thermocouple ) Grounded
- Standard ( RTD Pt100 ) 3-Wire 385 1/3DIN

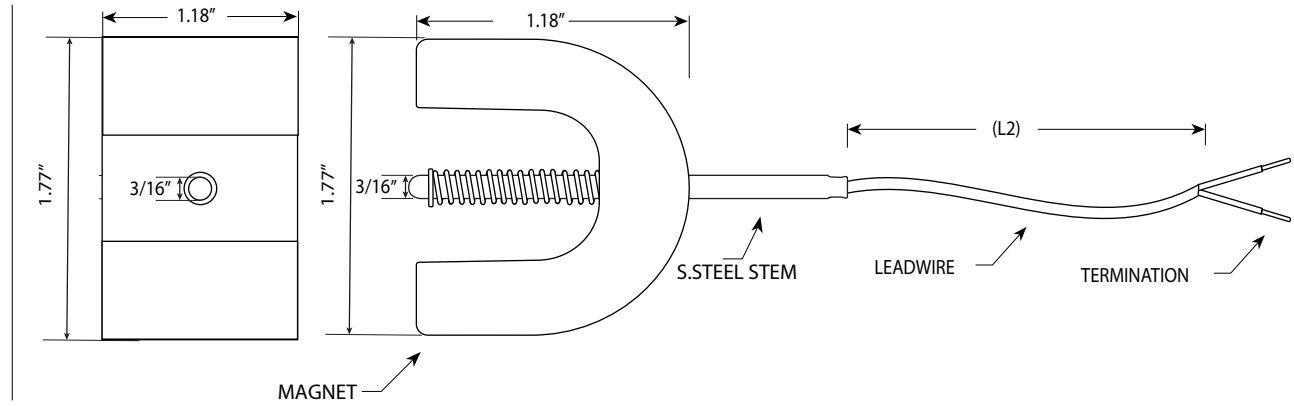

**PART NUMBER**

**M03TEF** - 

1
---

 - 

2
---

 - 

3
---

 - 

4
---

 - 

5
---

 - 

6
---

 - 

OPTIONS
---------

1 SENSOR TYPE	
R2	RTD Pt100 (MAX 260°C)
R5	RTD Pt100 (MAX 500°C)
K	TYPE K T/C
J	TYPE J T/C
T	TYPE T T/C
O ( )	OTHER (Specify)

4 LEADWIRE LENGTH (L2)
SPECIFY LENGTH IN INCHES

5 LEADWIRE INSULATION	
T	TEFLON (MAX 260°C)
TSS	TEFLON w/ SS OVERBRAID
C	COILED CHORD

6 LEADWIRE TERMINATION	
N	BARE LEADS
P	MINI PLUG
U	STANDARD PLUG
J	MINI JACK
A	STANDARD JACK
O ( )	OTHER (Specify)

OPTIONS	
U	UN-GROUNDED JUNCTION (ONLY APPLIES TO THERMOCOUPLES)
A	FLEXIBLE SS HOSE ARMOUR OVER LEADWIRE
R	TRANSITION FITTING w/ STRAIN RELIEF SPRING
D	DUAL SENSORS
O ( )	OTHER (Specify)